

## Description

Four pole switch or three pole switch/thermal circuit breaker (S-type TO CBE to EN 60934) with trip-free mechanism and red/green two button operation. Designed for snap-in panel mounting. Integral splash water protection to meet protection degree IP 66 in the operating area (option).

Optional with under voltage release module.

Complies with CBE standard EN 60934 (IEC 60934).

## Typical applications

High-pressure cleaners, shredders, pumps, power saws, electric tools, motors, processing systems.

## Approval logos



## Conformity



3140

## Technical data

For further details please see: [http://www.e-t-a.de/ti\\_e](http://www.e-t-a.de/ti_e)

Voltage rating	3 AC 415 V		
Current rating range	0.1...16 A		
Typical life	<b>3-pole</b>		
	3 AC 415 V: 0.1...14 A	10,000 operations at $1 \times I_N$ , inductive	
	15...16 A	10,000 operations at $1 \times I_N$ , resistive	
3 AC 415 V	<b>4-pole</b>		
	0.1...14 A	10,000 operations at $1 \times I_N$ , inductive	
	15...16 A	10,000 operations at $1 \times I_N$ , resistive	
Ambient temperature	-30...+60 °C (-22...+140 °F)		
Insulation co-ordination (IEC 60664 and 60664A)	rated impulse withstand voltage	pollution degree	
	2.5 kV	2	
	reinforced insulation in operating area		
Dielectric strength (IEC 60664 and 60664A)	test voltage		
	operating area	AC 3,000 V	
	between poles (3-pole)	AC 1,500 V	
Insulation resistance	> 100 MΩ (DC 500 V)		
Interrupting capacity $I_{cn}$	0.1...2 A	$10 \times I_N$	
	2.5...16 A	150 A	
Interrupting capacity (UL 1077)	$I_N$	$U_N$	3- and 4-pole
	0.1...16 A	AC 250 V	5,000 A
Degree of protection (IEC 60529/DIN 40050)	operating area IP40 (IP66 with water splash protection) terminal area IP00		
Vibration	5 g (57-500 Hz) $\pm$ 0.38 mm (10-57 Hz) to IEC 60068-2-6, test Fc, 10 frequency cycles/axis		
Shock	20 g (11 ms) to IEC 60068-2-27, test Ea		
Corrosion	96 hours at 5 % salt mist, to IEC 60068-2-11, test Ka		
Humidity	240 hours at 95 % RH, to IEC 60068-2-78, test Cab		
Mass	approx. 68		

## Approvals

Prüfstelle	Prüfnorm	Nennspannung	Nennstrombereich
UL	UL1077	AC 250 V DC 50 V	0,1...16 A (3-4 pole)
VDE	IEC/EN 60934	3 AC 415 V	0,1 A...16 A (3-4 pole)
CQC	GB 17701	AC 240/415 V	0,1 A...16 A (3-4 pole)
CSA	CSA C22.2, No. 235	AC 250 V DC 50 V	0,1 A...16 A (3-4 pole)

## Standard current ratings and typical internal resistance values

Current rating (A)	Internal resistance per pole ( $\Omega$ )	Current rating (A)	Internal resistance per pole ( $\Omega$ )
0.1	94	3.5	0.0595
0.2	24	4	0.0435
0.3	12	4.5	0.0325
0.4	5.30	5	0.0325
0.5	4.20	6	0.0215
0.6	2.90	7	0.0165
0.8	1.50	8	0.0125
1	0.9	10	< 0.02
1.2	0.80	12	< 0.02
1.5	0.45	14	< 0.02
2	0.27	15	< 0.02
2.5	0.0785	16	< 0.02
3	0.0595		

## Ordering information

<b>Type No.</b>	<b>3140</b> four pole switch or three pole switch/circuit breaker
<b>Mounting</b>	<b>F</b> snap in frame
<b>Frame</b>	<b>1</b> standard <b>2</b> splash water protected version
<b>Number of poles</b>	<b>3</b> 3-pole, thermally protected <b>7</b> 4-pole, thermally protected on 3 poles only
<b>Frame mounting</b>	<b>0</b> panel thickness 1-6.35 mm (.04-.25 in)
<b>Terminal design</b>	<b>P7</b> blade terminals 6,3x0.8 mm (QC 2x.110), DIN 46244-C <b>H7</b> as P7, additionally flat-head screw ISO 7045-M3.5 with +/- slot at terminal .1 (required with X3140-U)
<b>Characteristic curve</b>	<b>T1</b> thermal
<b>Switch style</b>	<b>S</b> 2 push buttons (ON/OFF)
<b>Switch colour</b>	<b>GRX</b> green/red
<b>Current rating range</b>	<b>0.1...16 A</b>

**3140 - F 1 3 0 - P7 T1 - S GRX - 10 A** ordering example

Please be informed that we have minimum ordering quantities to be observed.

## Dimensions

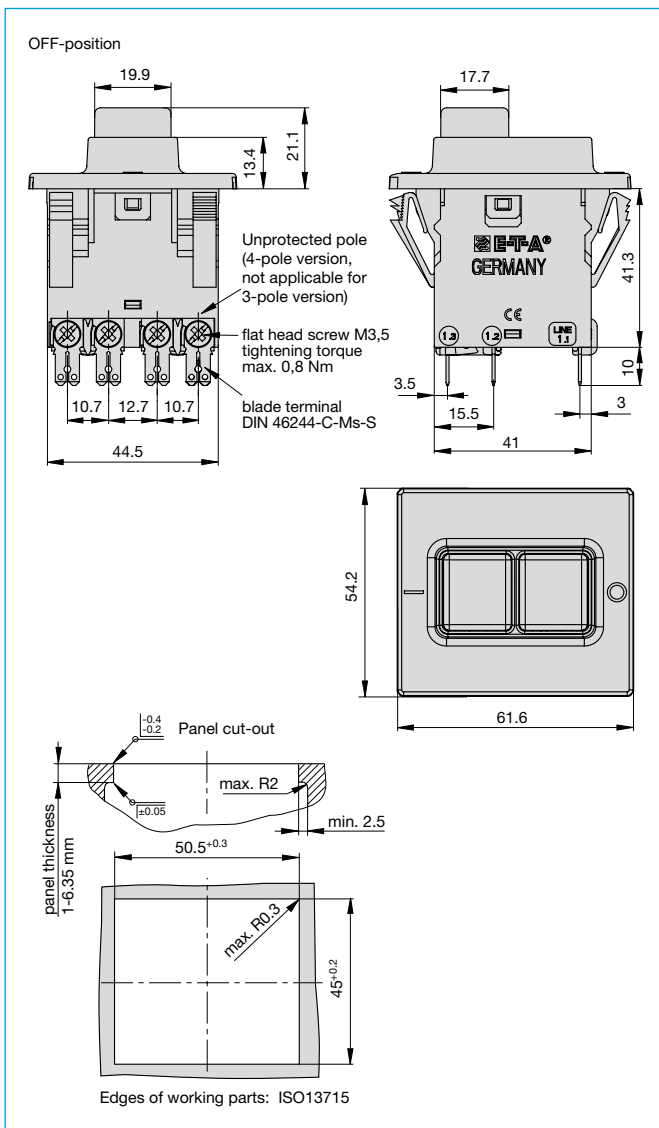

All dimensions without tolerances are for reference only. In the interest of improved design, performance and cost effectiveness the right to make changes in these specifications without notice is reserved. Product markings may not be exactly as the ordering codes. Errors and omissions excepted.

**Note: Terminal drawings**

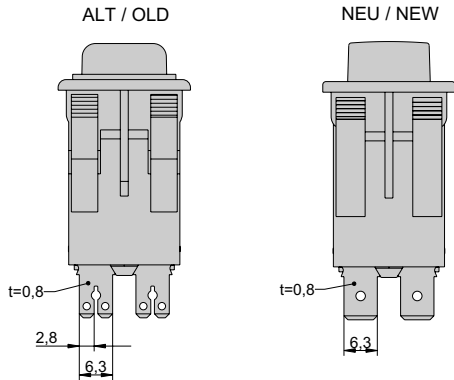

Note: The flat terminals are changed from slotted to unslotted from June 2026 onwards. This will not affect their shape, fit or function (the electromechanical specifications will remain the same). The order number remains the same as well. However, it will no longer be possible to attach receptacles for 2.8 x 0.8 mm. In some illustrations in this data sheet, the old version of the flat plug is still visible.

**Installation drawing**

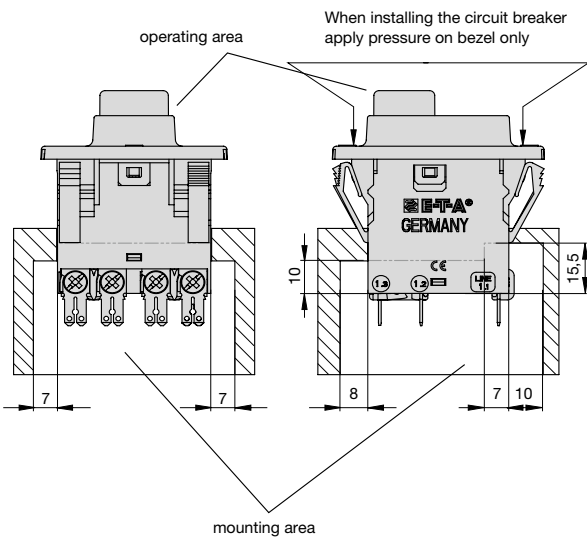

**Internal connection diagrams**

**3-pole thermally protected**

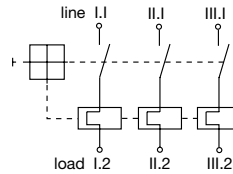

**4-pole 3-poles thermally protected**

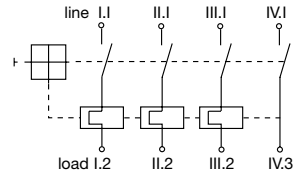

**Typical time/current characteristics**

**0.1...2 A**

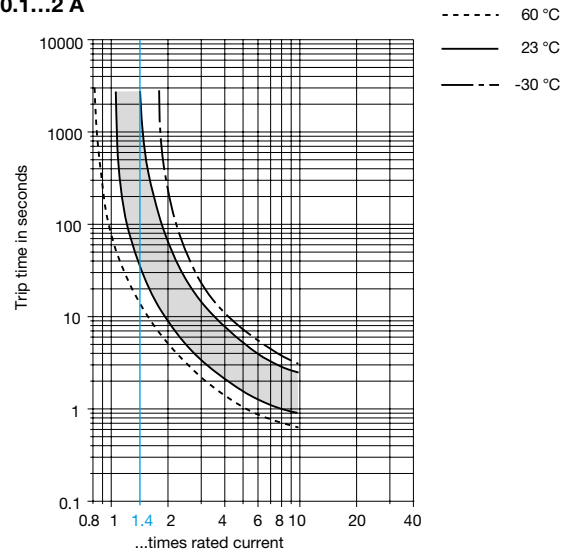

**2.5...16 A**

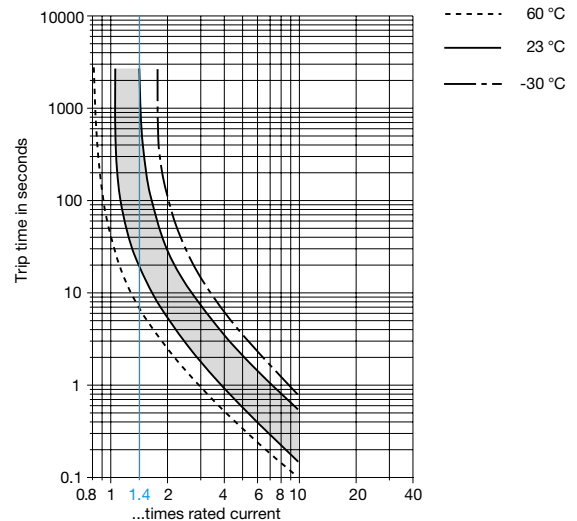

The time/current characteristic curve depends on the ambient temperature prevailing. In order to eliminate nuisance tripping, please multiply the circuit breaker current ratings by the derating factor shown below. See also section Technical information.

Ambient temp. °F	-22	-4	+14	+32	+73.4	+104	+122	+140
°C	-30	-20	-10	0	+23	+40	+50	+60
Derating factor	0.8	0.76	0.84	0.92	1	1.08	1.16	1.24

This is a metric design and millimeter dimensions take precedence (mm / inch)

## Description

A module suitable for all versions of type 3140 to trip the main switch/ circuit breaker mechanism in the event of loss of voltage of the connected phases. When the voltage is restored the switch must be reset to reconnect the load, thereby avoiding the safety hazards associated with automatic re-starting of machinery.

**Note:** Basic unit 3140-... must be fitted with -H7 or -G7 screw terminals.

**US patent number:** US 6,714,396 B2

## Typical applications

Machines such as power tools, industrial equipment and domestic appliances where automatic restart after restoration of power could be dangerous (EU Machinery Directive).

## Ordering information

<b>Type No.</b>	
<b>X3140</b>	Module for type 3140
<b>Function</b>	
<b>U</b>	undervoltage release module
<b>Terminal design</b>	
<b>00</b>	standard (without separate connections)
<b>01</b>	one blade terminal 2.8x0.8 (QC .110)
<b>Voltage ratings</b>	
<b>00</b>	AC 400 V 50/60 Hz
<b>03</b>	DC 24 V
<b>09</b>	AC 230 / 240 V 50/60 Hz
<b>Assembly status</b>	
<b>M</b>	module mounted to the circuit breaker
<b>X3140 -U 00 00 M</b> ordering example	

## Technical data

Voltage ratings	AC 400 V 50/60 Hz; AC 230 V; DC 24 V
Voltage tolerance	+10%/-15%
Current consumption	approx. 2.0 mA
Release values	$0.2 \times U_N < U < 0.7 \times U_N$ (at a rated voltage of AC 400 V the device may release at 280 V and must release at 80 V)
Release delay	$t < 20$ ms
Latch-in values	$\geq 85 \% U_N$
Ambient temperature	-30...+60 °C (-22...+140 °F)
Vibration	5 g (57-500 Hz) $\pm$ 0.38 mm (10-57 Hz) to IEC 60068-2-6, test Fc 10 frequency cycles/axis
Shock	20 g (11 ms) to IEC 60068-2-27, test Ea
Corrosion	48 hours at 5 % salt mist, to IEC 60068-2-11, test Ka
Humidity	240 hours at 95 % RH to IEC 60068-2-78, test Cab
Mass	approx. 90 g (complete assembly)

## Dimensions

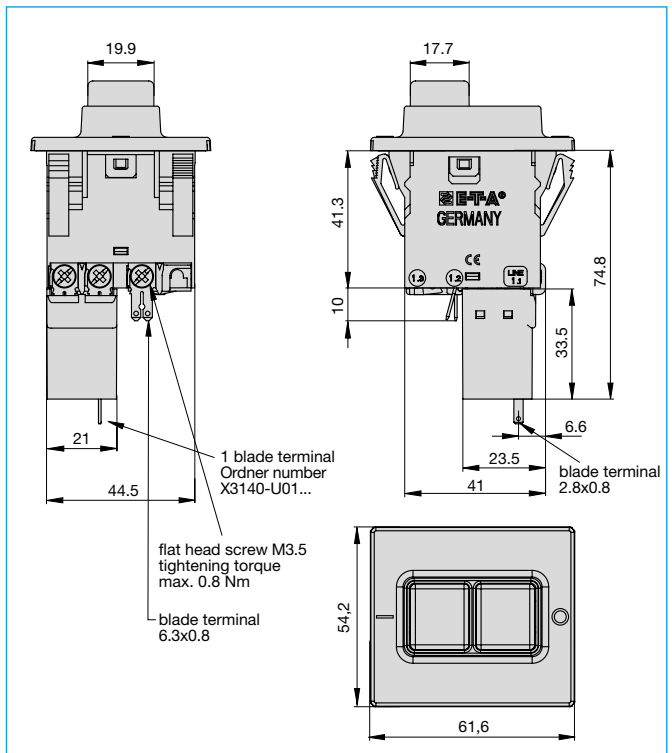

## Internal connection diagrams

### X3140-U00

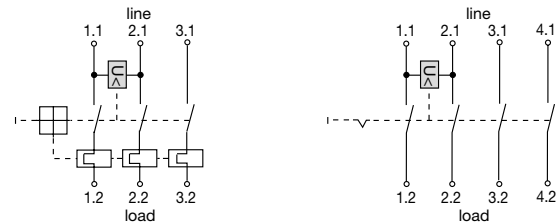

### X3140-U01

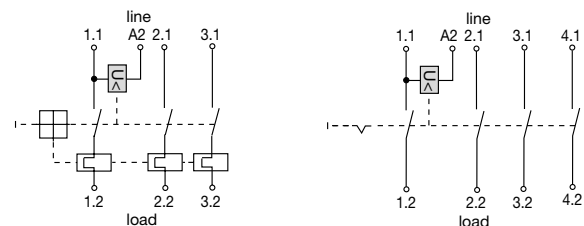

## Approvals (complete circuit breaker/module assembly)

Authority	Standard	Rated voltage
VDE	IEC/EN 60934	AC 42...400 V DC 24 V

This is a metric design and millimeter dimensions take precedence ( $\frac{mm}{inch}$ )

All dimensions without tolerances are for reference only. In the interest of improved design, performance and cost effectiveness the right to make changes in these specifications without notice is reserved. Product markings may not be exactly as the ordering codes. Errors and omissions excepted.